

Guidance - Rolling Test Configurations

Configurations

Pure rolling test configurations can be divided into three basic categories:

Bearing Test Geometries

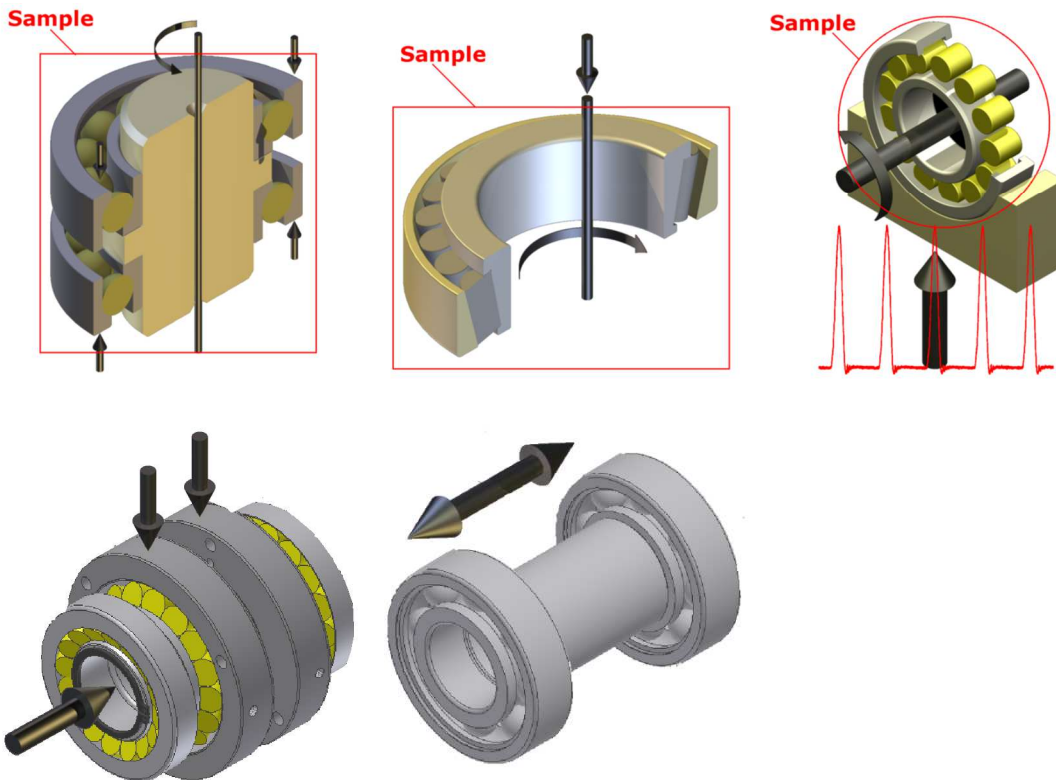

These tests use standard rolling element bearings as the test component. Tests may form the basis either for life testing the bearing itself or for evaluating the performance of a lubricant or grease.

Idealized Component Test Geometries

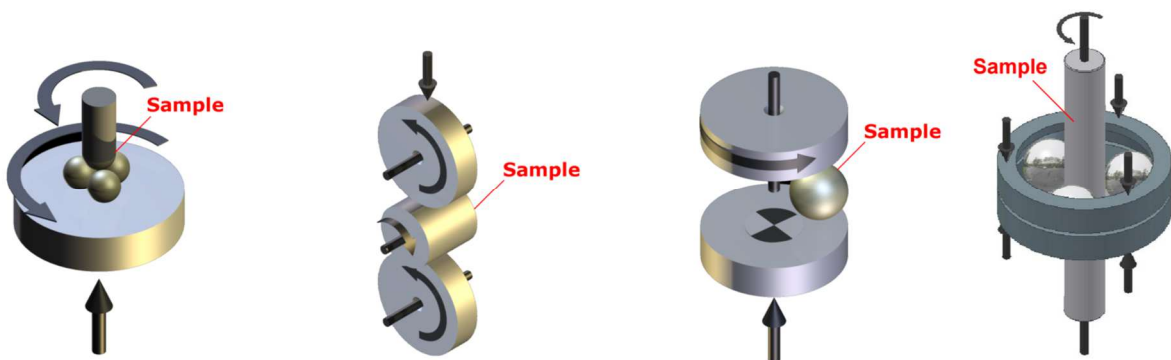

These tests are aimed at stressing a single rolling element component, either a ball or a rod. These tests are used for both material and lubricant tests.

Hybrid Component Test Geometries

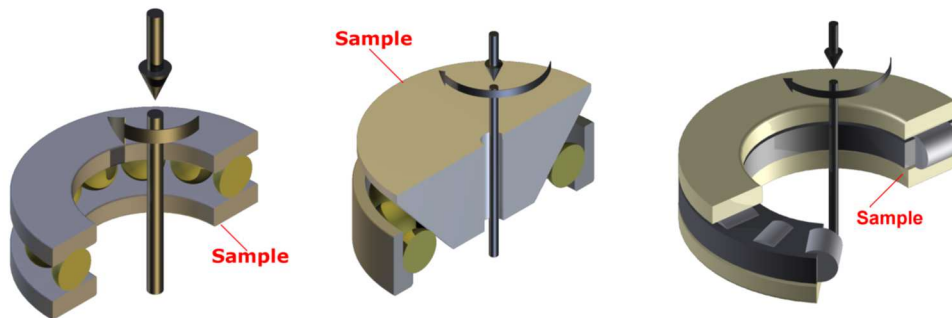

The hybrid test geometries are used for evaluating both rolling elements and race-way materials, using the rolling elements and one race-way from standard rolling element bearings. In the roller thrust bearing set-up, the lower race is replaced with a flat disc of candidate test material and in the angular contact bearing set-up, the upper race is replaced with a cone of candidate test material.

Axial Loading versus Radial Loading

The basic issue with choosing a rolling contact fatigue test configuration is to choose which component you wish to fail first: the rolling element or the race?

With a radially loaded bearing, assuming a non-rotating bearing outer shell, the outer race will tend to fail before the balls or rollers. This is because the balls or rollers are only loaded intermittently, as they pass through the point of loading. By contrast, with an axially loaded test geometry, the balls or rollers are continuously loaded.

Reduced Complement Tests

With both axially loaded bearing and hybrid test geometries, the preferential failure component can be switched from race material to rolling elements, by reducing the number of balls or rollers in the contact. For each rotation, each rolling element is subjected to the same number of fatigue cycles, but with a reduced number of balls or rollers, the races are subjected to fewer fatigue cycles.

As the minimum complement is three equi-spaced balls or rollers, it makes sense to choose test bearings that normally accommodate multiples of three balls or rollers.

Of course, running a radially loaded bearing, with reduced complement of rolling elements, does not work.

Machines

TE 92HS Microprocessor Controlled Rotary Tribometer - High Speed

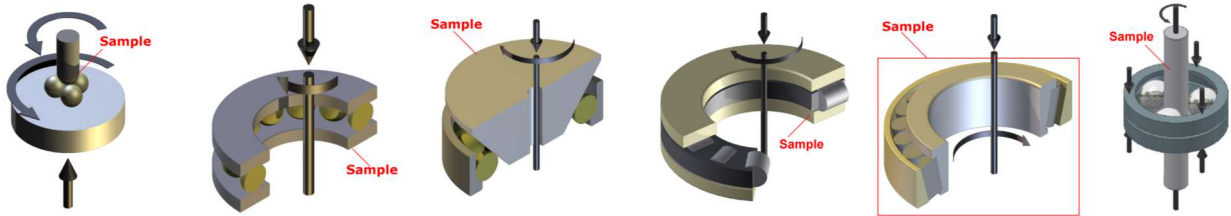

Rolling Four Ball

Ball Thrust Washer

Cone on Angular Contact Bearing

Roller Thrust Washer

Taper Roller Bearing

Ball on Rod

RCF 3 Rolling Contact Fatigue Machine - Radial Loading

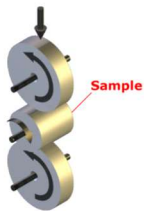

Twin Roller on Rod Specimen

RCF 4 Rolling Contact Fatigue & Bearing Friction Rig

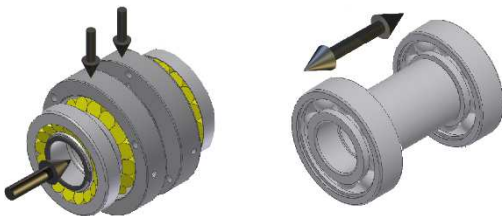

Combined Radial and Axial Loading

Bi-directional Axial Loading

TE 91 Precision Rotary Vacuum Tribometer

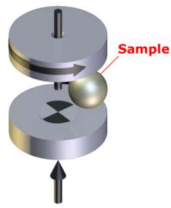

Spiral Orbit Tribometer

RCF 5 Rolling Contact Fatigue Machine – 3,000 rpm

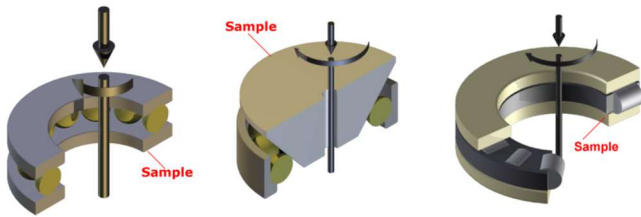

RCF 6 Three Ball on Rod Rolling Contact Fatigue – 15,000 rpm

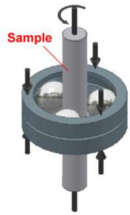

RCF 7 Rolling Contact Fatigue Machine – 10,000 rpm

